

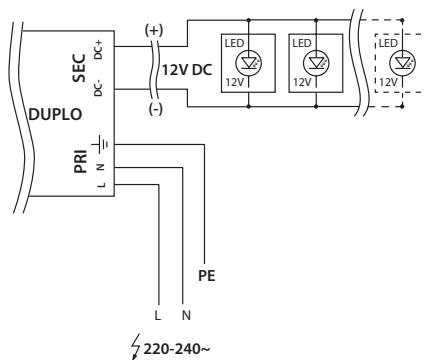

DUPLO LED 100W

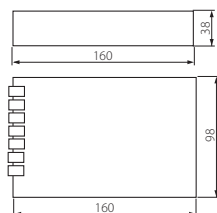

- ▶ struttura: alluminio anodizzato
- ▶ boîtier: aluminium anodisé

			PRI	SEC		
DUPLO LED 100W	19380	cromo / chrome	220-240V~; 50/60Hz	DC 8,3A (12V); 0..100W	1-/12	484

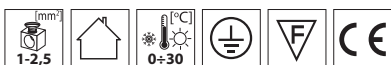

stabilizzazione tensione 12V DC / la temperatura massima ammissibile della struttura è 75°C / protezione da corto circuito integrata / sistemi di riduzione delle interferenze radioelettriche integrati / trasformatore di sicurezza resistente al corto circuito
 stabilisation d'une tension 12V DC / température maximale admissible du boîtier 75°C / protection contre court-circuit incorporée / systèmes de réduction des perturbations radioélectriques incorporés / transformateur de sécurité résistant aux court-circuits

